

Reel Tape Cutter Manual

ESER EU900SA

Universal Part Number: 52474801, Rev. -

Issued 10/11

Book 1 of 1

**PRODUCT
DOCUMENTATION**

REEL TAPE CUTTER

MODEL: EU900SA

OPERATING MANUAL

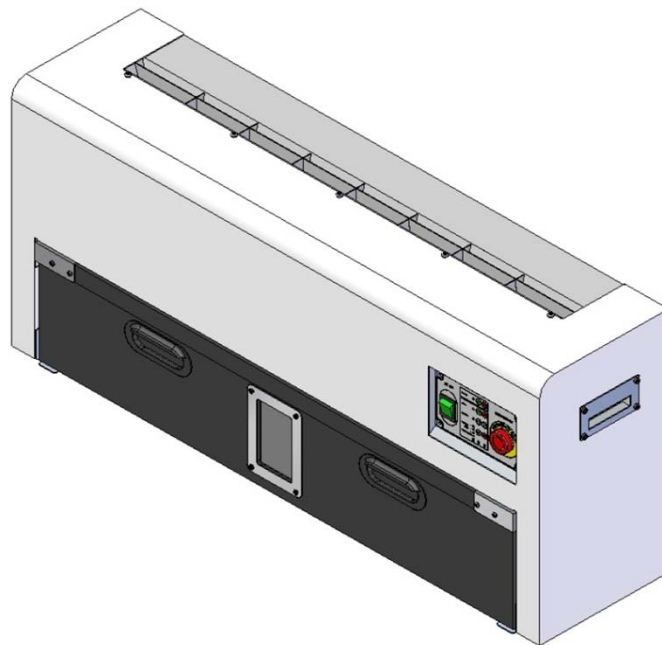
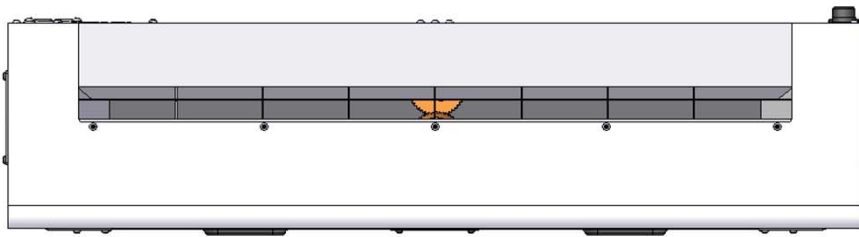

TABLE OF CONTENTS

OVERALL DIMENSION -----	1
FUNCTIONAL DESCRIPTION -----	2
PRODUCT SAFETY -----	2
OPERATION -----	3
Operate the Scrap Tape Cutter -----	3
Operating Panel -----	3
Setting Zone -----	5
Setting Cycle Time -----	6
Automatic Mode -----	7
Manual Mode -----	7
ADJUSTMENT -----	8
Recover from jam -----	8
Empty the Trash Bin -----	8
MAINTENANCE CONCEPT -----	9
MAINTENANCE -----	10
A. Remove the Rear Cover -----	11
B. Remove the Inlet Guide -----	12
C. Remove the Cutting Mechanism -----	13
1. Adjust the Belt Tension -----	14
2. Replace the Timing Belt -----	15
3. Replace the Blade -----	17
4. Lubricate the Helical Gear -----	20
5. Lubricate the LM Guide -----	21
6. Replace the PCB -----	22
7. Replace the Magnetic Sensor Controller -----	23
SPECIFICATIONS -----	24
WIRING DIAGRAM	
Circuit Layout -----	25
Main Circuit -----	26
AC Power Line -----	27
Sub Board -----	28
PART NUMBERS -----	29
Major Components -----	29
Cutting Mechanism -----	30
1. Drive Side -----	31
2. Cutting Unit -----	32
3. Idle Side -----	35
AUXILIARY PARTS WITH A NEW MACHINE -----	36

OVERALL DIMENSION



← 900 →

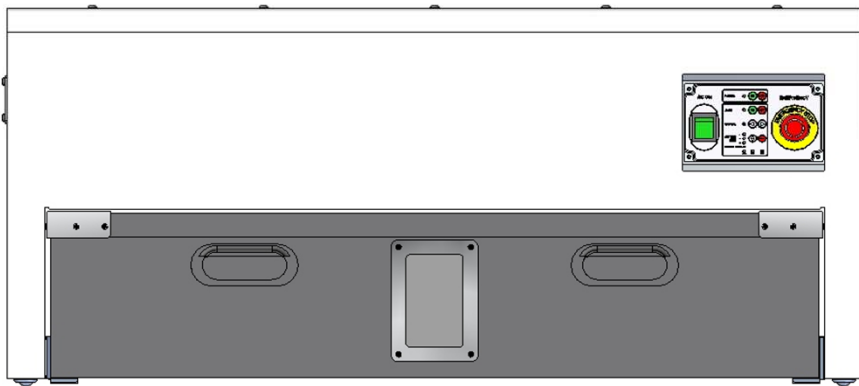

↑
400
↓



← 220 →

Unit: mm

FUNCTIONAL DESCRIPTION

The Scrap Tape Cutter is designed to cut off small pieces of reel tape and collect them in a trash bin for ease of disposal. This document explains important safety information, as well as proper operation and maintenance of the unit.

PRODUCT SAFETY



WARNING

- **Do not put objects other than reel tape in the cutter unit.**
- **Use caution with long hair and when wearing loose clothing near the cutter unit.**
- **Unplug the unit when performing maintenance of the machine.**
- **Do not operate the machine near flammable gas.**
- **Do not open/disassemble the cutter unit while the machine is operating.**
- **Follow all safety labels on the cutter unit.**

OPERATION

Operate the Scrap Tape Cutter

The Scrap Tape Cutter has two modes of operation; manual and automatic. Manual mode should only be used when trying to cut objects that jammed the unit when it was operating in automatic mode. This could be an indication the blade needs replacement. Otherwise, the cutter should be used in automatic mode.

The Operating Panel

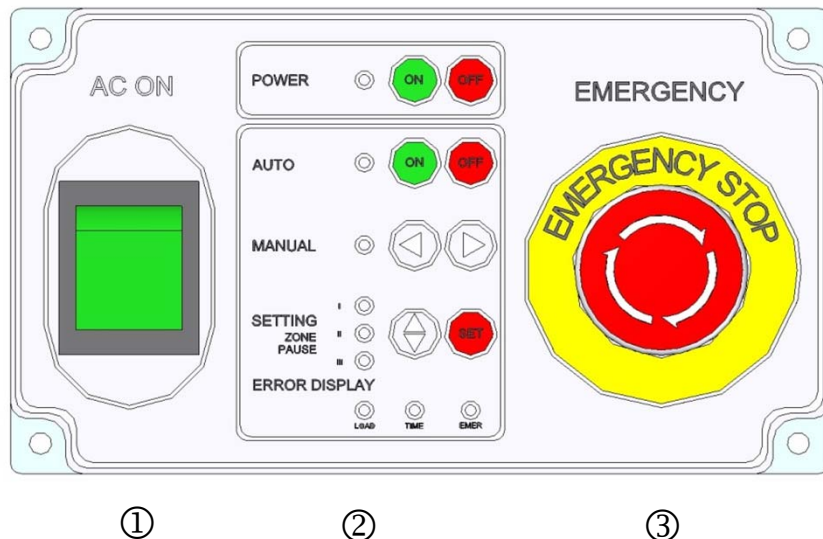

- ① Main Power Switch
- ② Operation Control
- ③ Emergency Stop Button

OPERATION

The Operating Panel cont.

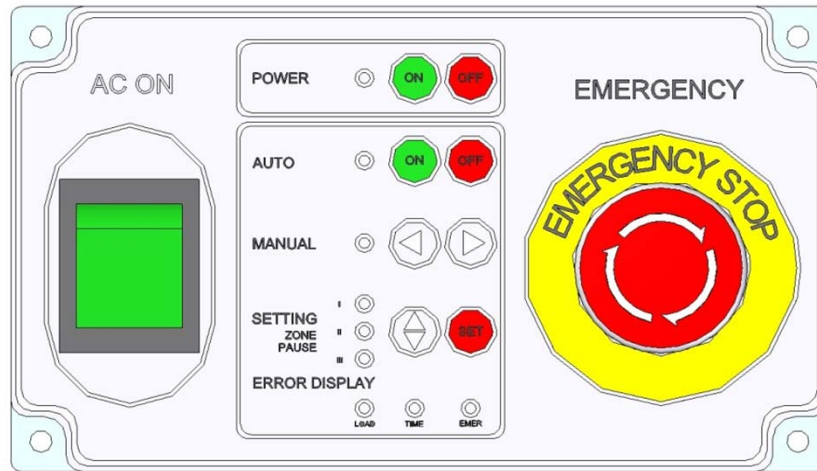

②

② Operation Control

POWER: Cutter power on and off

AUTO: Auto – Manual Mode switch

MANUAL: Cutting mechanism move manually

SETTING: Set Cutting Zone and Pause Time

ERROR DISPLAY: Indicators for Load, Time, Emergency

OPERATION

Setting Zone

Three zones are preset at factory and select any one of the zones or combination of zones to set desired cutting length. There are 6 ways to specify the cutting zone as follows:

Note the zone indicator light stay lit as unit is in operation.

1. I: First zone only (Left, opposite from control panel)
2. II: Second zone only (Middle)
3. III: Third zone only (Right, control panel side)
4. I & II: combination of zones I and II; blade travels across zone I and II, does not reach zone III.
5. II & III: combination of zones II and III; blade travels across zone II and III, skip zone I.
6. I,II,& III: combination of all zones; blade travels entire length of the cutter.

Setting Procedure

1. Turn power off by pushing [OFF] button at POWER.
2. Turn power on by pushing [ON] button at POWER.
3. Push [SET] button at SETTING.
4. Push [upper/lower arrow] button once at a time until the desired zone setting is achieved, see above light setting. Make sure the indicator light stays lit; 1 light for single zone, multiple lights for combination of zones.
5. Push [ON] button at AUTO. Resume auto cutting.

OPERATION

Setting Cycle time

Three pausing times are preset at factory and designated as (I) short, (II) Medium, and (III) Long.

Note the pause time indicator light blinks as it is being set.

Setting Procedure

1. Turn power off by pushing [OFF] button at POWER.
2. Turn power on by pushing [ON] button at POWER.
3. Push [SET] button twice at SETTING. Make sure LED indicator light blinks.
4. Push [upper/lower arrow] button once at a time to select desired pause time setting.
5. Push [ON] button at AUTO. Resume auto cutting.

OPERATION

Automatic Mode

1. Rotate the Emergency Stop switch.
2. Push [ON] button at AUTO. The blade unit begins to move. The blade continues to cycle until the collection bin is removed or the Emergency Stop switch is pushed.

If the unit jams, the blade automatically backs up and tries again. If the unit is still jammed after a second attempt, the machine will stop and a buzzer will sound. The jam must be cleared using manual mode before the unit can be returned to operating in automatic mode.

Manual Mode

1. Rotate the Emergency Stop switch.
2. Push and hold the Left or Right Directional Arrow button. The unit stops once the blade reaches the limit of travel.

ADJUSTMENT

Recover From Jam

Use the following procedure to clear a jam.

1. Push the Emergency Stop switch to stop the buzzer.
2. Rotate the Emergency Stop switch.
3. Turn power on by pushing [ON] button at POWER.
4. Push and hold the Left or Right Directional Arrow button to move the blade back away from the jam.
5. Push the Emergency Stop switch and clear the jam.
6. Rotate the Emergency Stop switch.
7. Turn power on by pushing [ON] button at POWER.
8. Push [ON] button at AUTO. Resume auto cutting.

Empty the Trash Bin

Use the following procedure when emptying the Scrap Tape Cutter collection bin.

1. Grasp the handles on the trash bin and slide the bin out from the Scrap Tape Cutter unit. The cutter automatically stops.
2. Empty and then re-install the trash bin. Push the [ON] button at AUTO to resume operation.

MAINTENANCE CONCEPT

The following table defines the recommended Maintenance Concept for this assembly.

Maintenance Procedures	Recommended Frequency	Minimum Skill Required	Spare Kit Required	Tool Kit Required
Empty Trash Bin	As required	Operator, Maintenance Technician	No	No
Replace Blade	As required	Maintenance Technician	No	No
Helical Gear	Check in 3 months	Maintenance Technician	No	No
LM Shaft Lubrication	As required	Maintenance Technician	No	No
Belt Tension	Adjust as required Check monthly	Maintenance Technician	No	No

MAINTENANCE

To execute the following maintenance items, the initial 3 disassembly steps, A, B, & C shown in the next section must be performed first.

1. Adjust the Belt Tension
2. Replace the Timing Belt
3. Replace the Blade
4. Lubricate the Helical Gear
5. Lubricate the LM Guide
6. Replace the PCB
7. Replace the Magnetic Sensor Controller

MAINTENANCE



PUSH EMERGENCY SWITCH AND UNPLUG THE UNIT BEFORE DISASSEMBLE/ASSEMBLE

A. Remove the Rear Cover

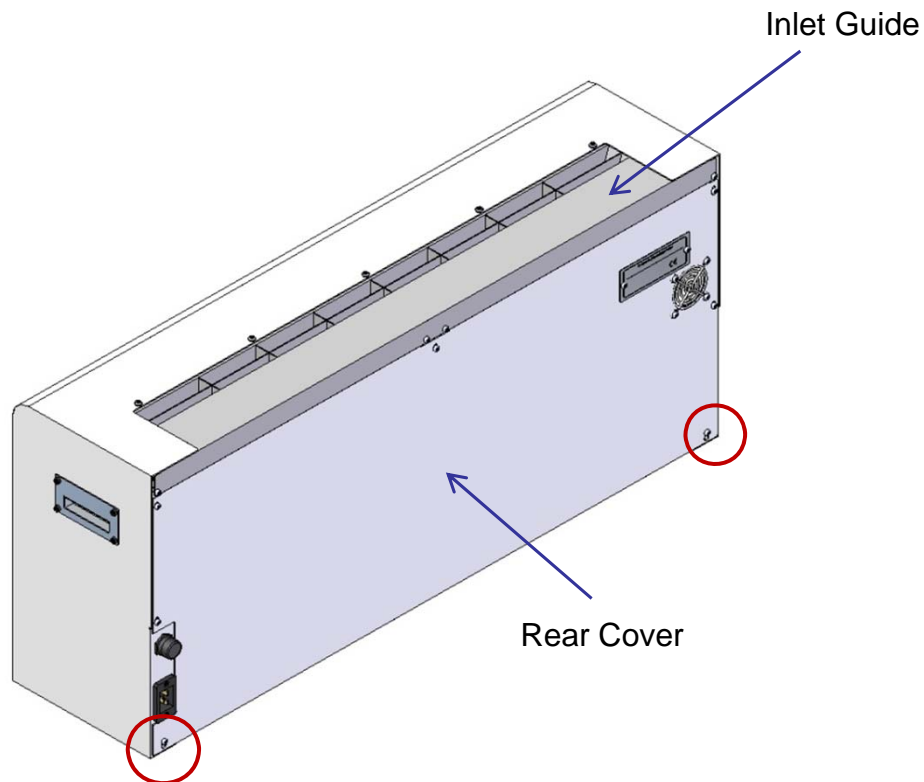

1. Loosen 2 bolts circled in red at the bottom of the rear cover.
2. Remove 5 bolts on the rear cover.
3. Remove the cover.

MAINTENANCE

B. Remove the Inlet Guide

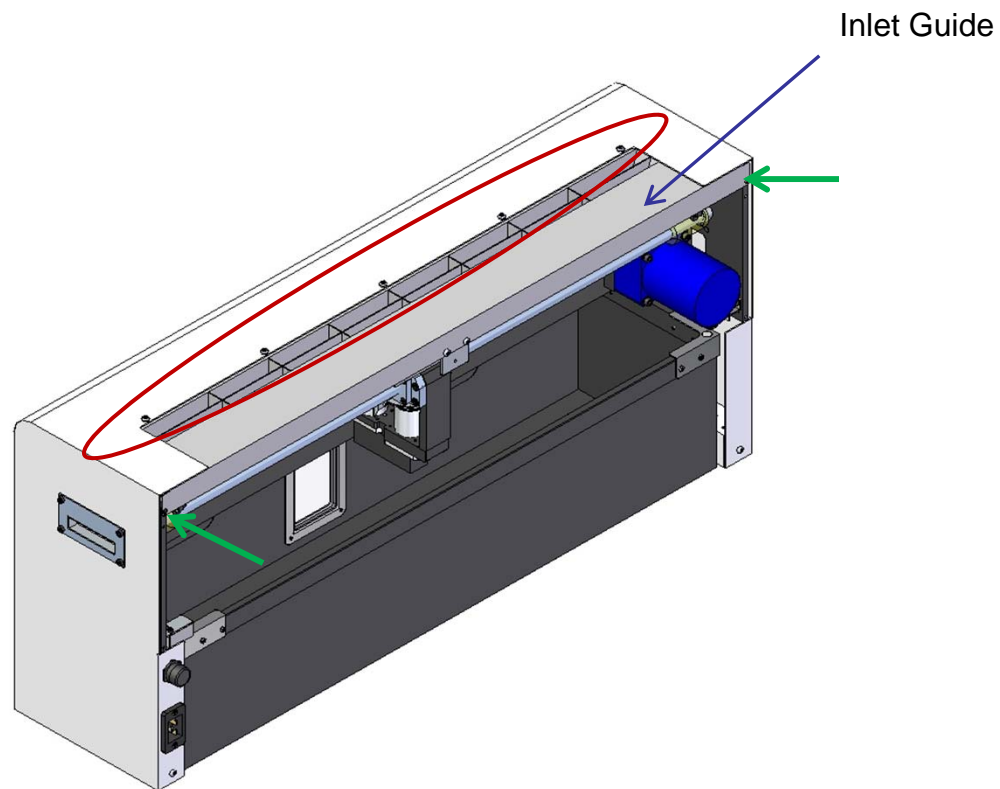

1. Remove 2 bolts, green arrow, at both ends of the inlet guide, do not remove 2 bolts at center.
2. Loosen 5 bolts on top of the machine, red circle.
3. Remove the inlet guide

MAINTENANCE

C. Remove the Cutting Mechanism

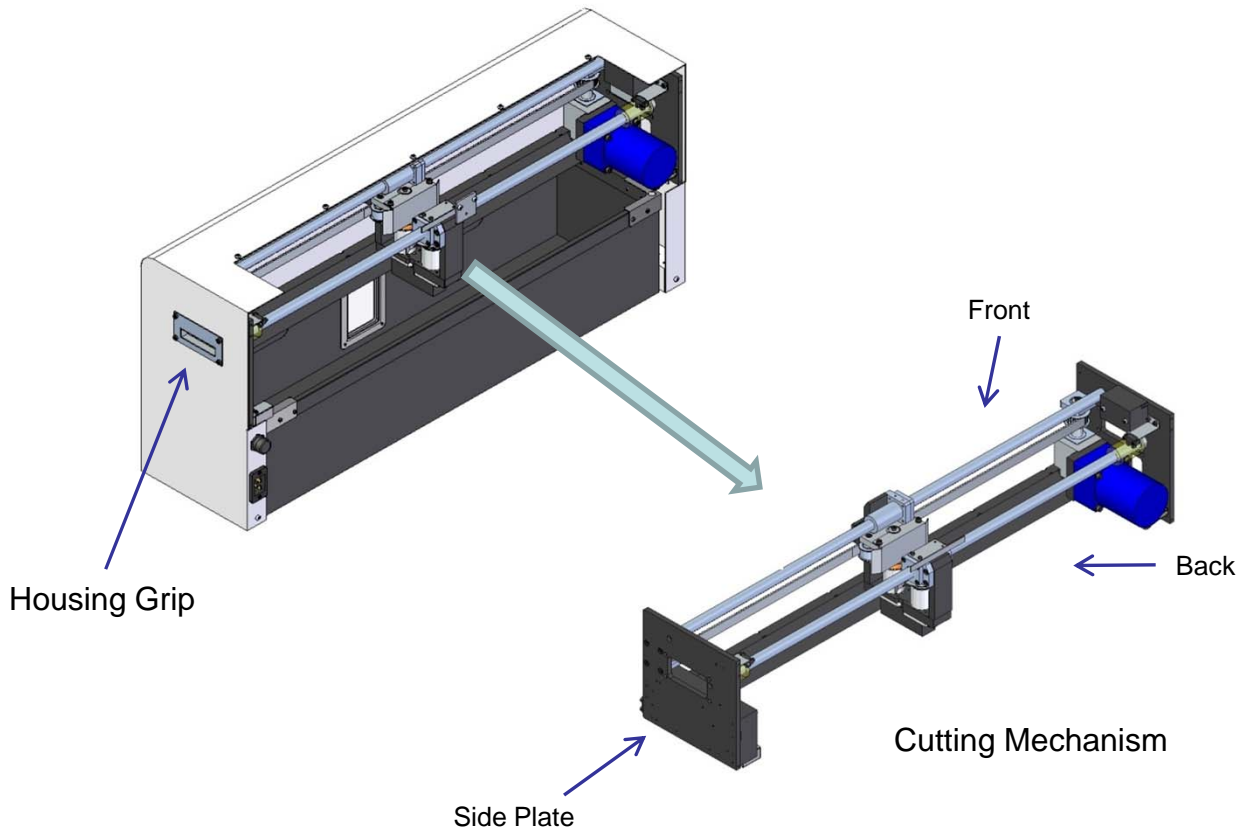
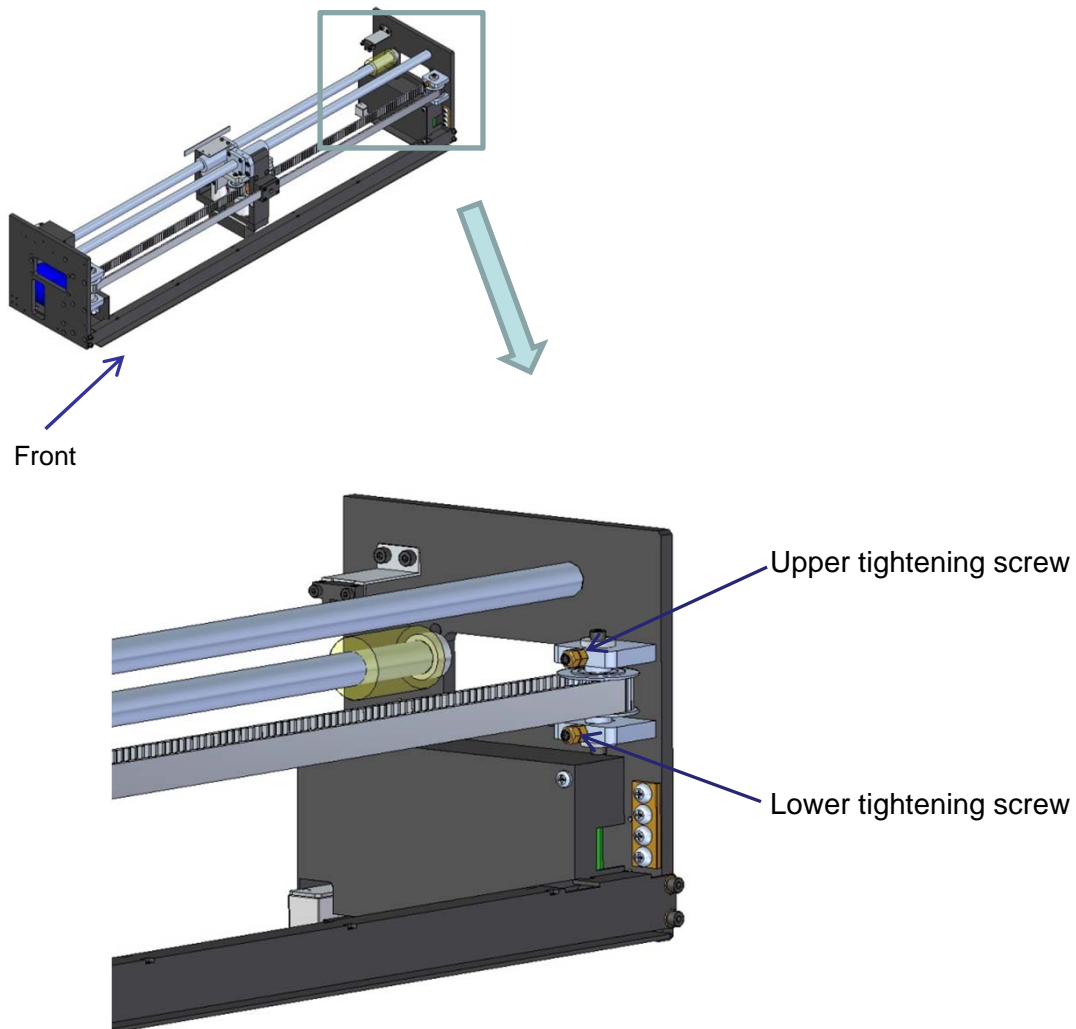

Diagram does not show any electrical wires and ties. Cut ties and loosen necessary electrical wires must be done before sliding out the cutting mechanism.

1. Remove Trash Bin.
2. Remove 4 M4 cap screws and grip from housing located at side of the machine. Repeat the same for opposite side.
3. Remove 2 M4 bolts located at the bottom of side plate, inside, attached to the housing. Repeat the same for opposite side.
4. Slide out the mechanism.

MAINTENANCE

1. Adjust the Belt Tension



1. Loosen 4 locknuts.
2. Apply tension to the timing belt by evenly tightening two set screws to remove excess slack from the belt. Pushing the belt lightly, 600g (1.3lb) at the center with cutting unit at the end of the machine. The belt should have approximately 1 cm deflection at the center.
3. Tighten locknuts.

MAINTENANCE

2. Replace the Timing Belt

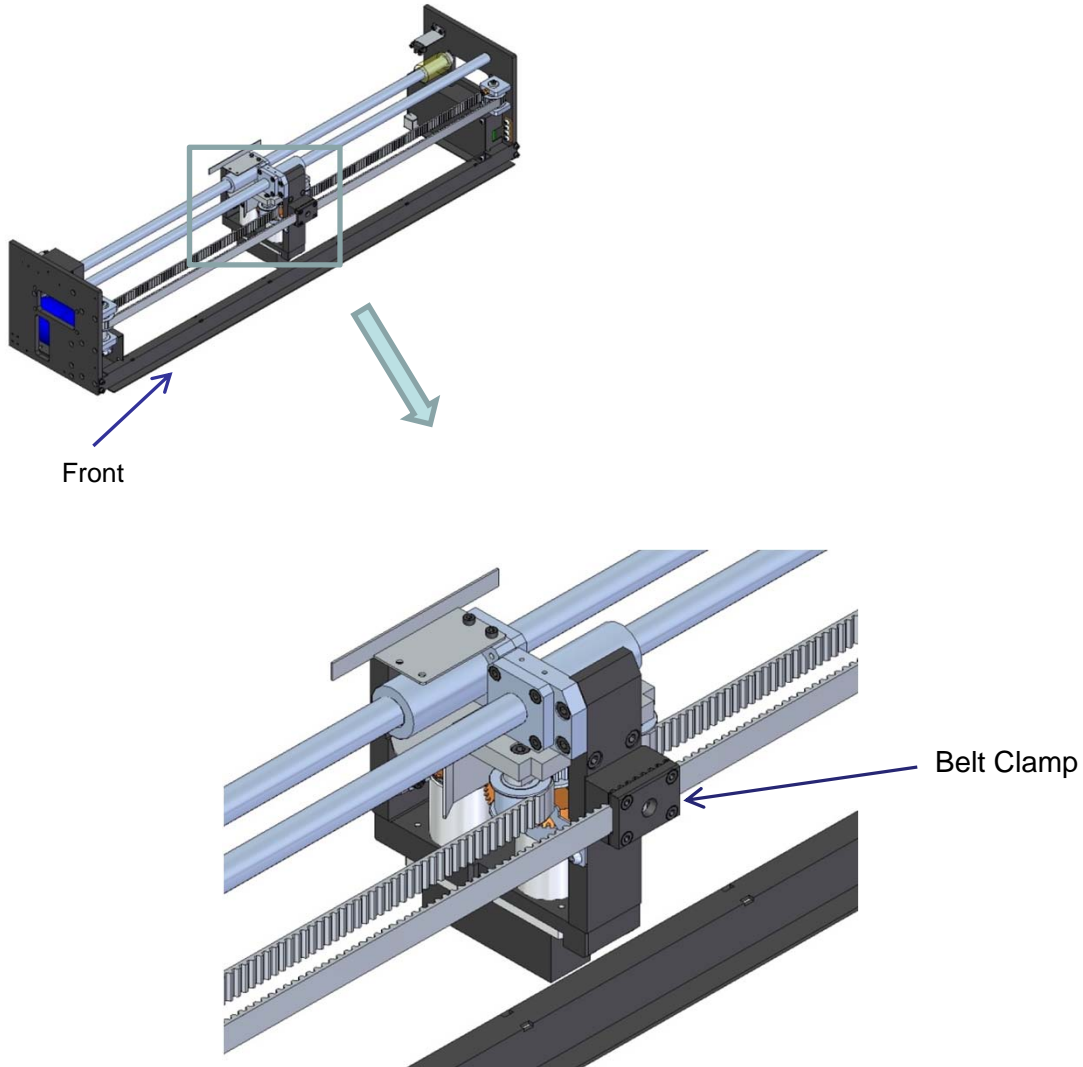

1. Remove 4 M4 cap screws holding the belt clamp
2. Remove the belt clamp.

MAINTENANCE

2. Replace the Timing Belt cont.

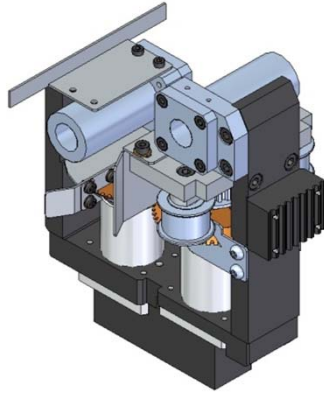

3. Remove old belt.

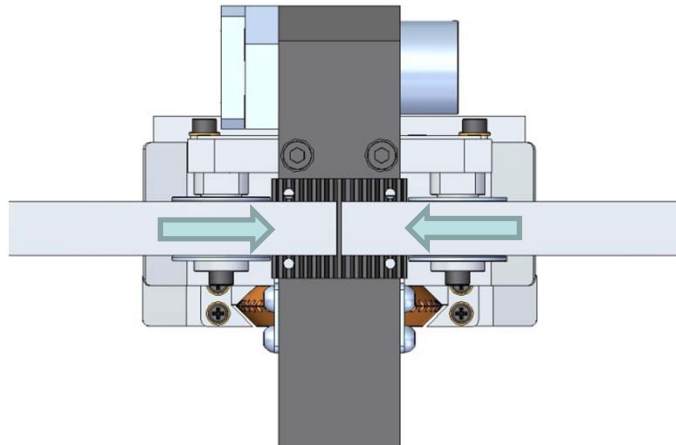

4. Cut new belt in proper length as shown, no gap but no overlap of the belt.
5. Mount the belt clamp.
6. Insert 4 M4 cap screws and tighten.
7. Adjust belt tension, refer to "Belt Tension Adjustment" in section 1.

MAINTENANCE

3. Replace the Blade

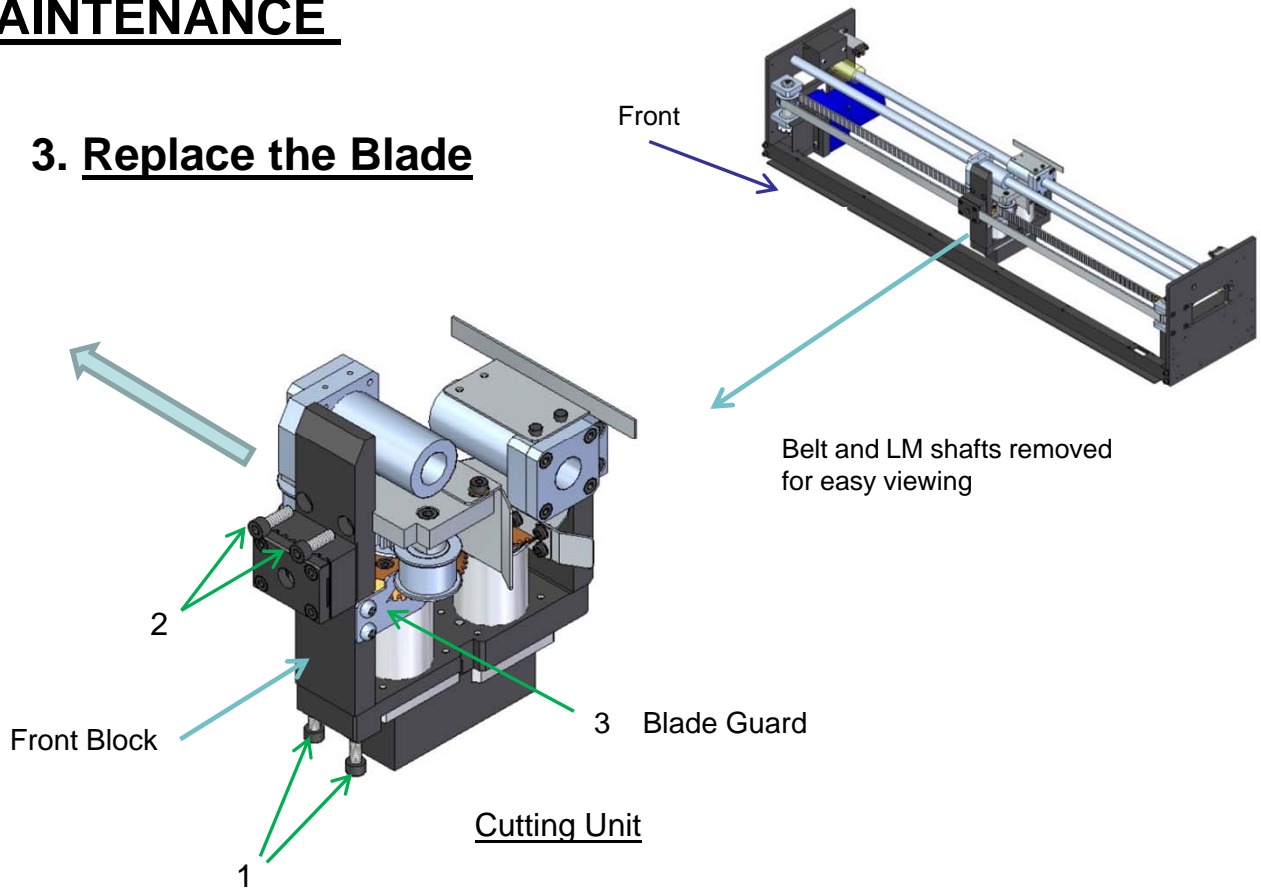

1. Remove 2 M5 cap screws, access from the bottom.
2. Remove 2 M5 cap screws.
3. Remove 2 screws and the blade guard.
4. Slide the Front Block as direction shown.

Slider Support Plate, sub-assy.

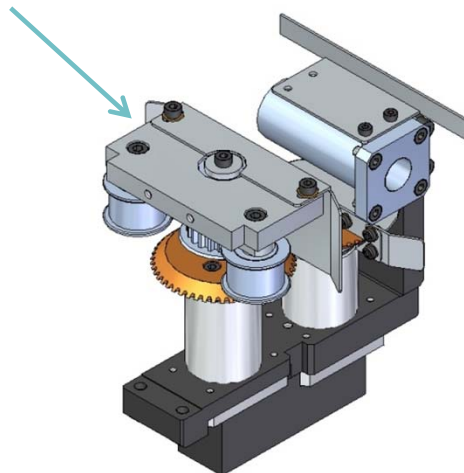

5. Remove Slider Support sub-assy.

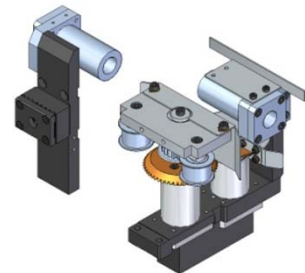

MAINTENANCE

3. Replace the Blade cont.

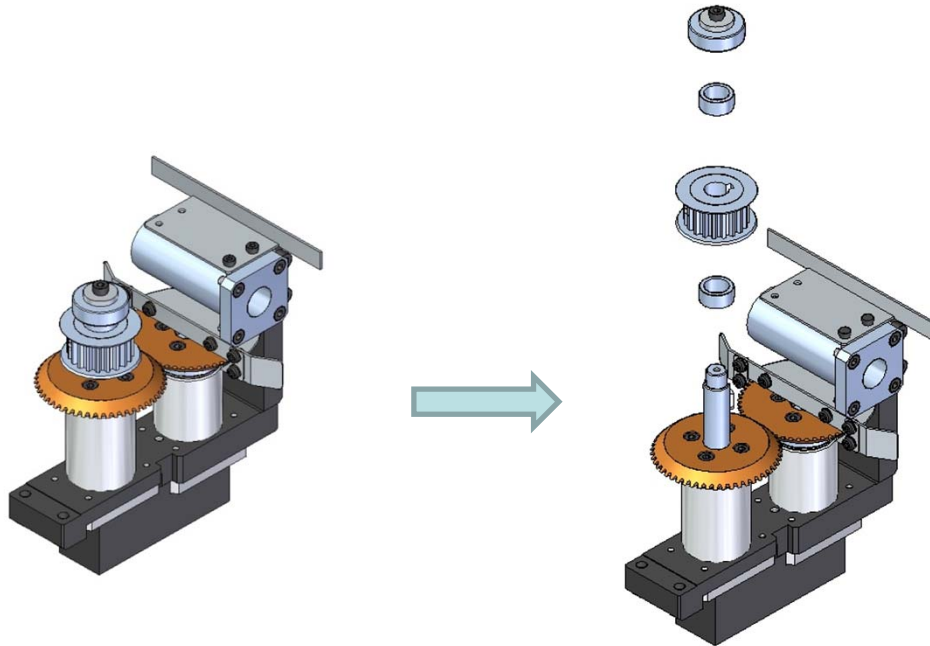

6. Disassemble the parts as shown

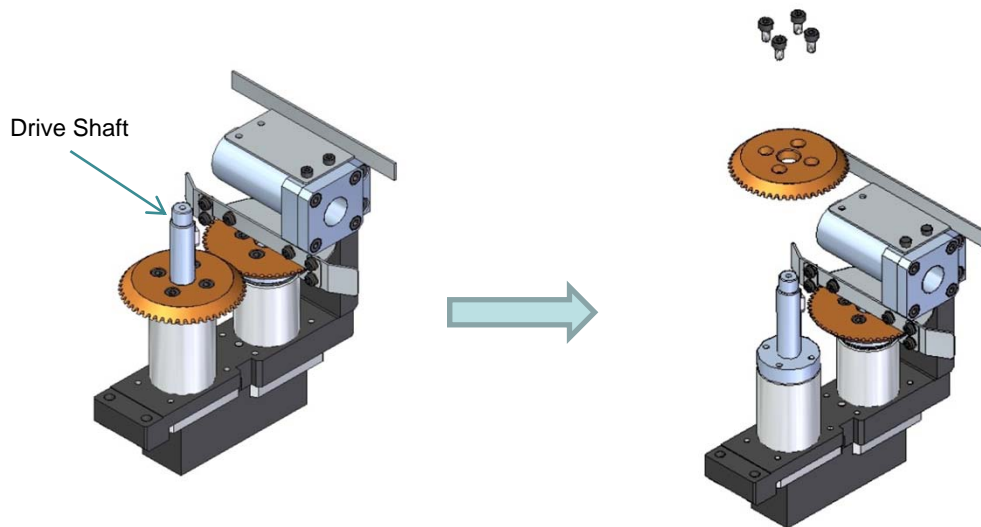

7. Remove 4 M4 cap screws and the upper blade as shown. Note; hold the drive shaft to prevent the blade from rotating as the screws being loosened.

MAINTENANCE

3. Replace the Blade cont.

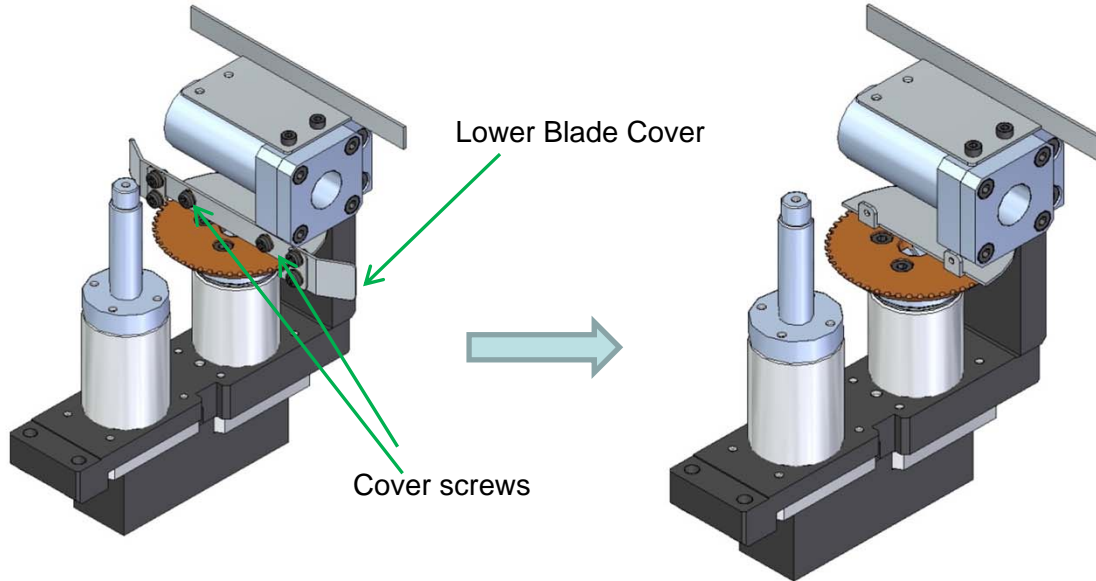

8. Remove cover screws and the lower blade cover.

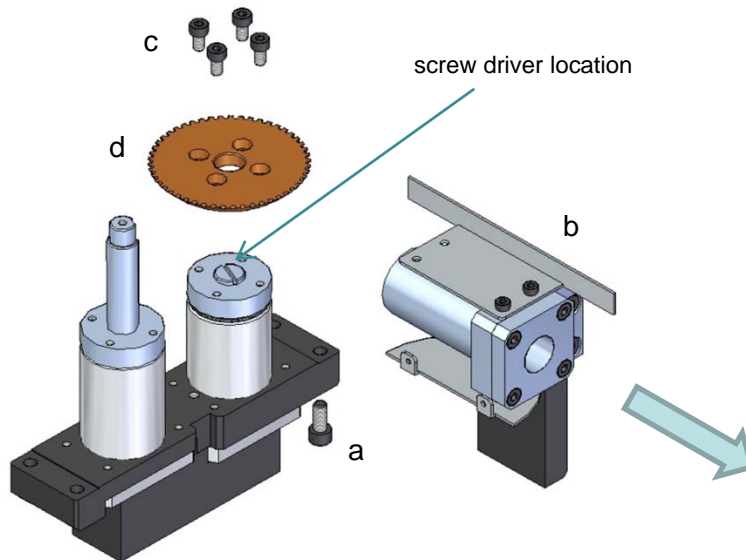

9. Lower Blade Removal

- a. Remove 2 M5 cap screws, access from the bottom.
- b. Slide LM bearing unit.
- c. Remove 4 M4 cap screws.*
- d. Remove Lower Blade.

Note: * use a screw driver to prevent from the blade from rotating as the cap screws being loosened.

10. Reverse above procedures for assembly.

MAINTENANCE

4. Lubricate the Helical Gear

1. Flip over the mechanism to see the bottom.

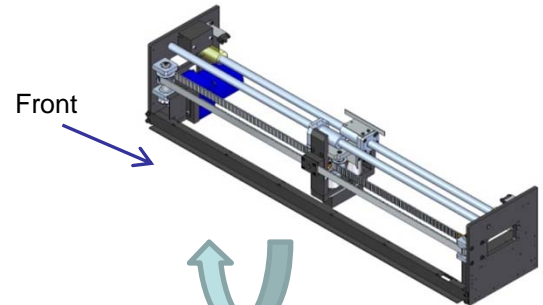

2. Remove 2 M4 cap screws and Gear Cover.

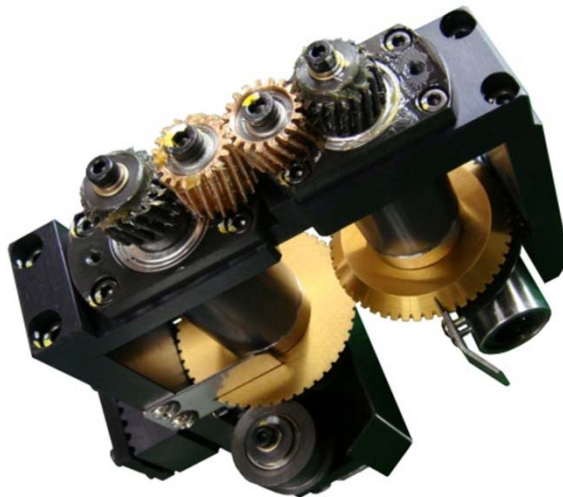
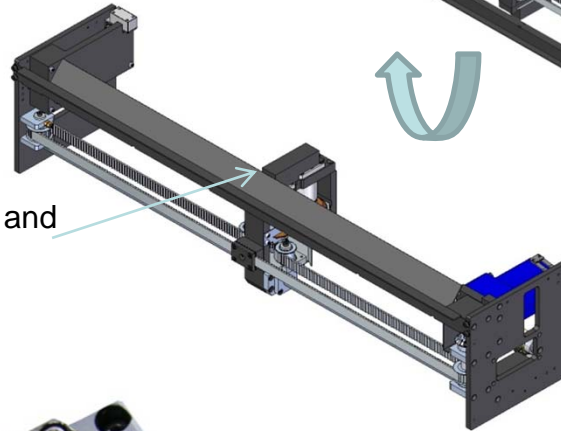

Showing helical gears after removal of the protective cover.

3. Clean gears by removing foreign particles, apply grease after cleaning.
Note: disassembly of gears may not be necessary for cleaning however if an excessive wear and/or damaged gears were detected, it is recommended to replace entire helical gears at once.
4. Assemble parts in reverse order after maintenance.

MAINTENANCE

5. Lubricate the LM Guide

Apply grease lightly to LM shafts, DO NOT over grease.

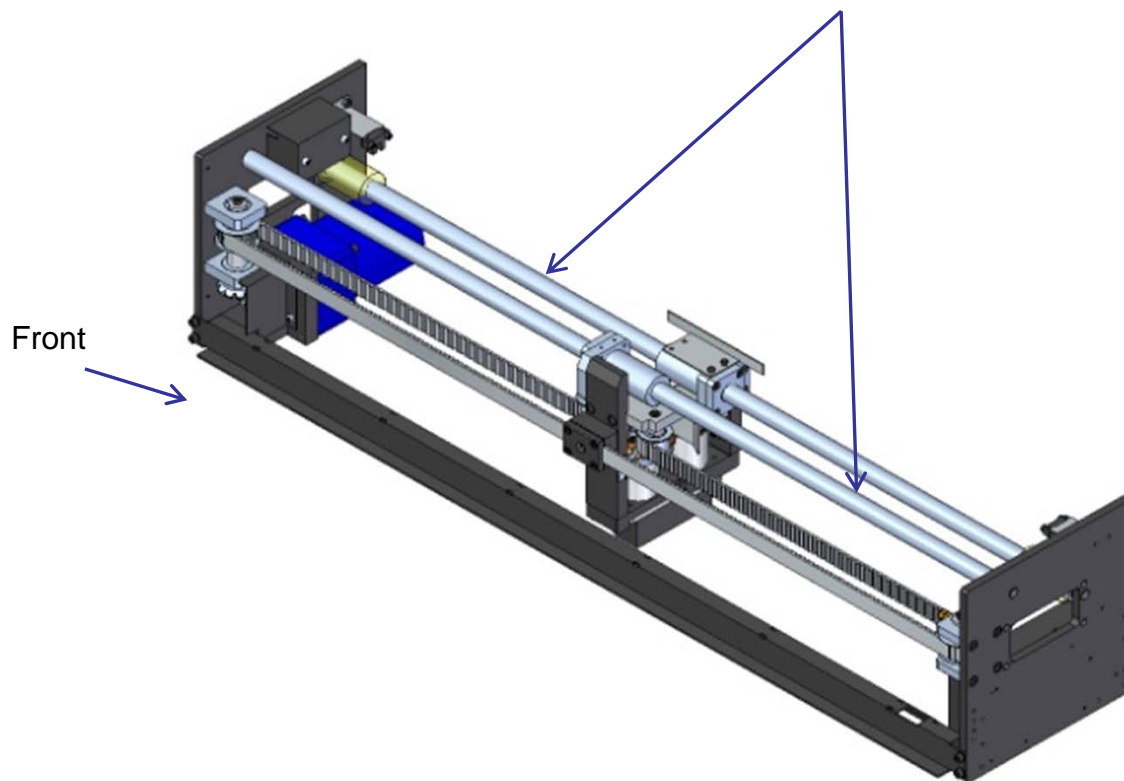

MAINTENANCE

6. Replace the PCB

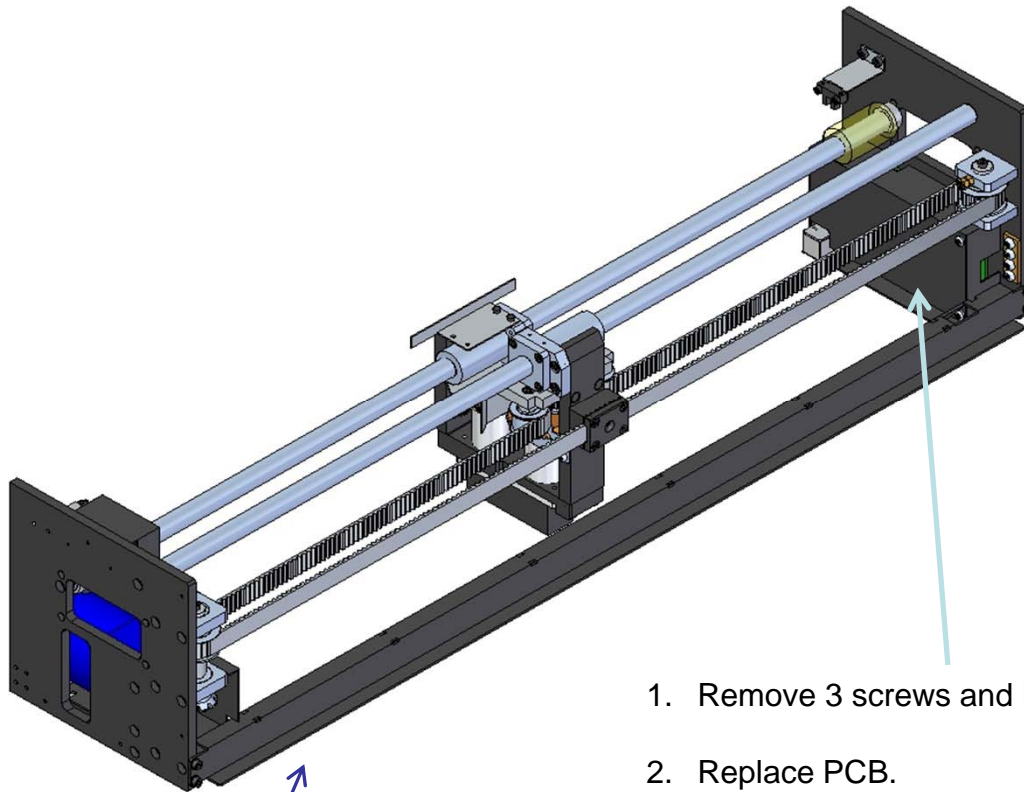

Front

1. Remove 3 screws and PCB Cover.
2. Replace PCB.
(Detail ref. to part number section)

MAINTENANCE

7. Replace the Magnetic Sensor Controller

1. Remove 2 screws and Controller Cover.
2. Replace Controller (small PCB)
(Detail ref. to part number section)

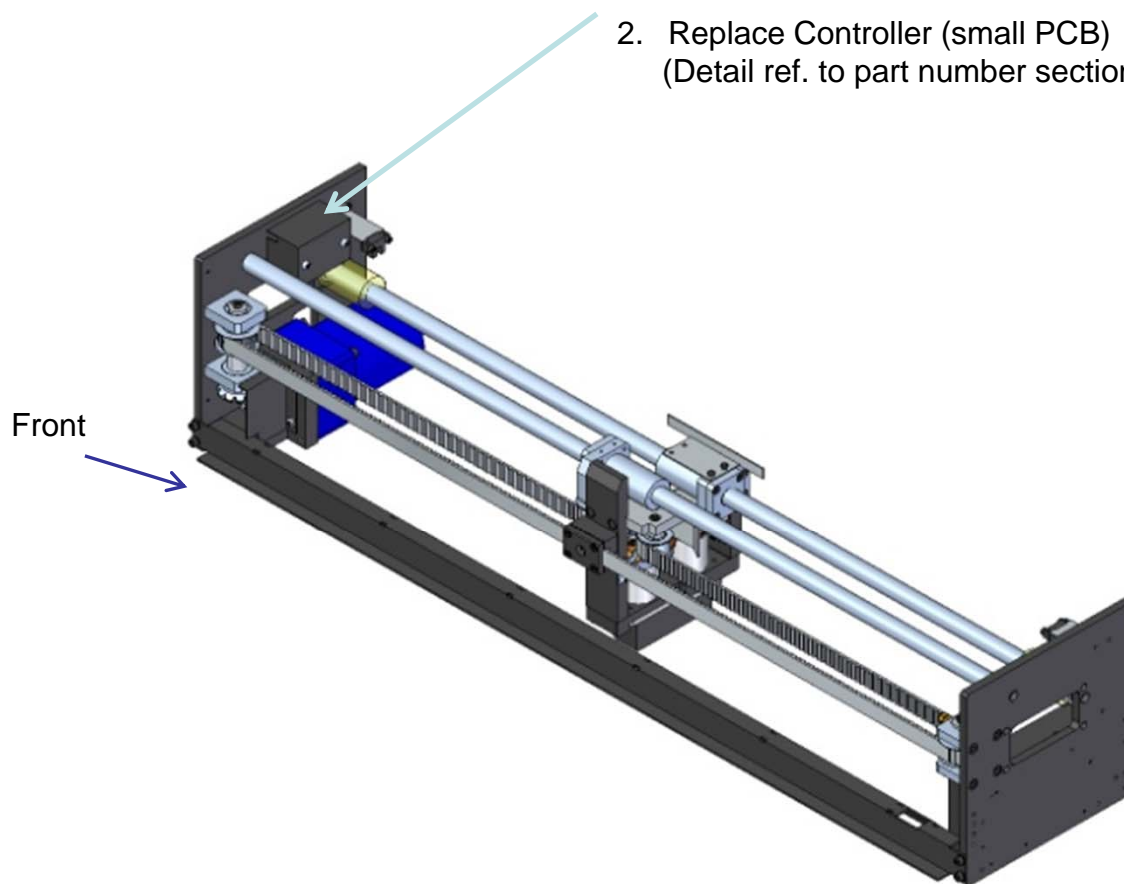

Specifications

No	Item	Specification
1	Cutting Mechanism	Rotational Circular Gear Blades
2	Available Tape	Paper Tape (8~32mm)
		Embossed Plastic, Other. Very thin vinyl tape not recommended.
3	Cutting Speed	76 mm/sec.
4	Pause time	2, 6, 10 second, preset at factory.
5	Effective Cutting Length	755 mm
6	External Dimension	900 x 220 x 400 (L x W x H)
7	Collection Bin	815 x 215 x 175 (L x W x H)
8	Total Weight	28 Kg
9	Noise Level	Lower than 70dB (new)
10	Main Power Supply	220VAC (Single Phase, 50/60Hz)
11	Electric Consumption	100W
12	Control System Type	MCU (Micro Computer Unit)
13	Motor Spec.	15W, 220VAC 50/60Hz, Gear Head 1/40

CIRCUIT LAYOUT

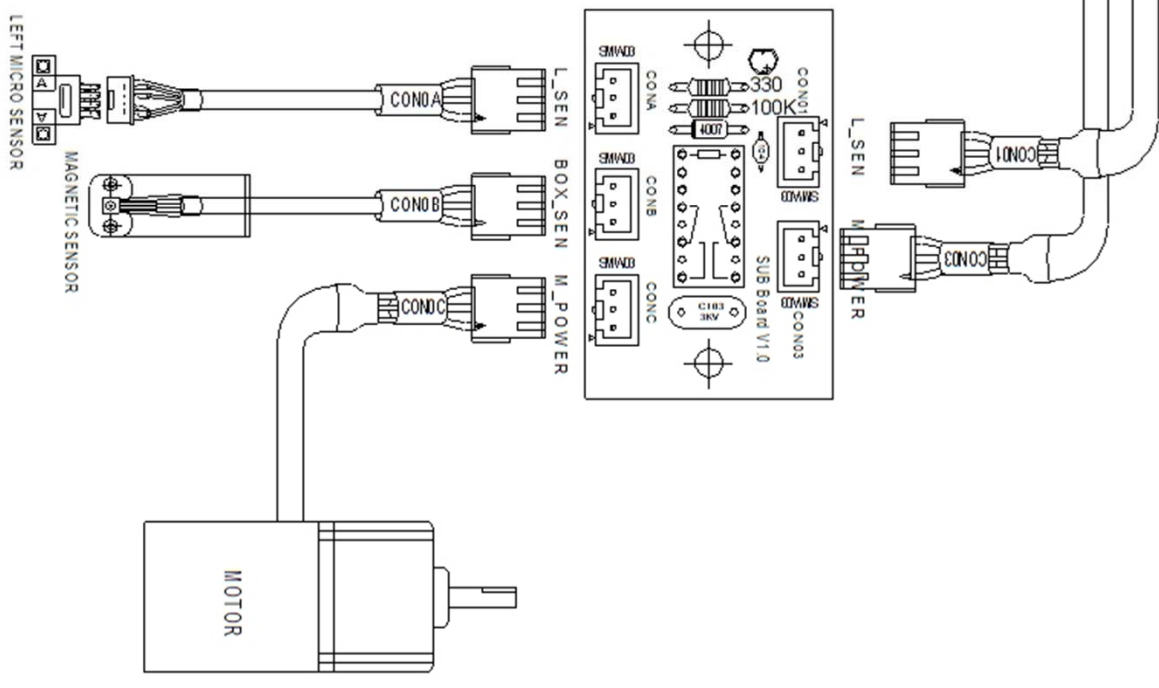
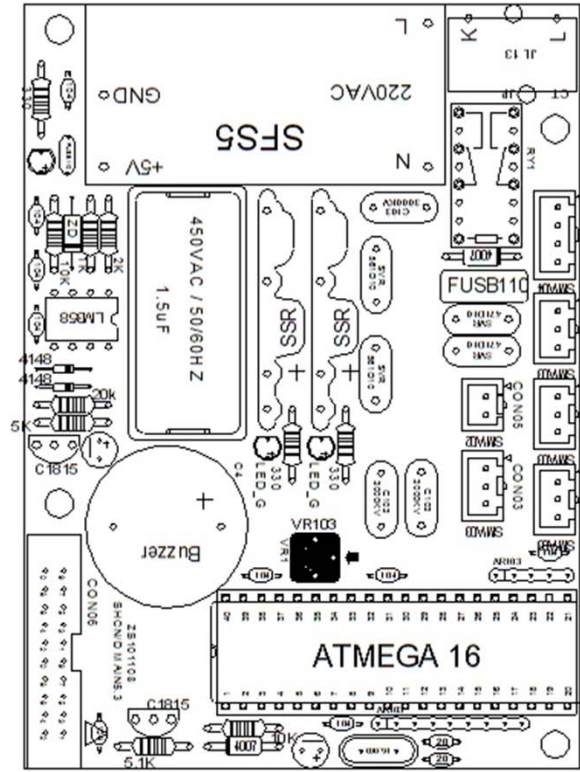

MAIN CIRCUIT

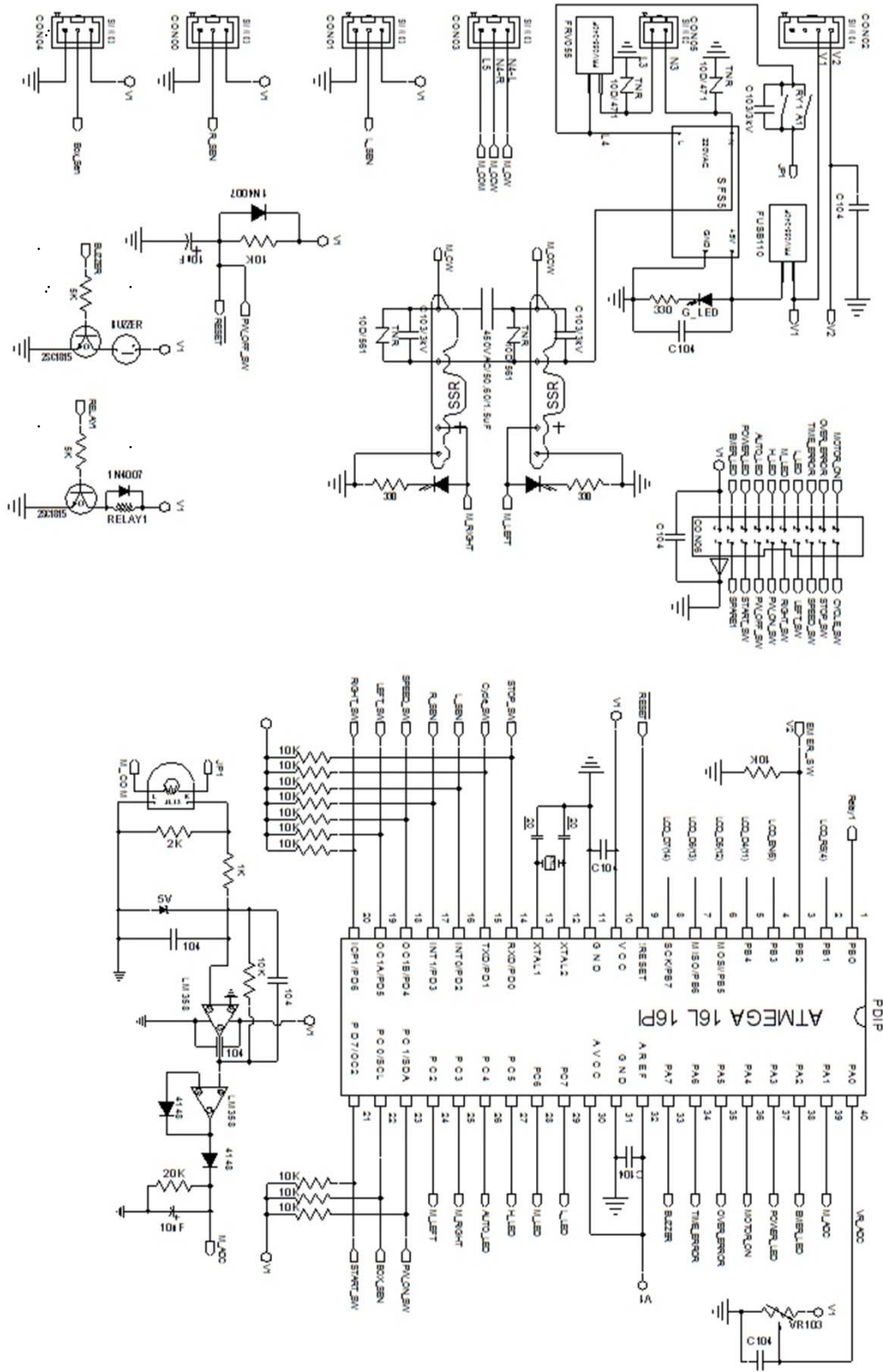

AC POWER LINE

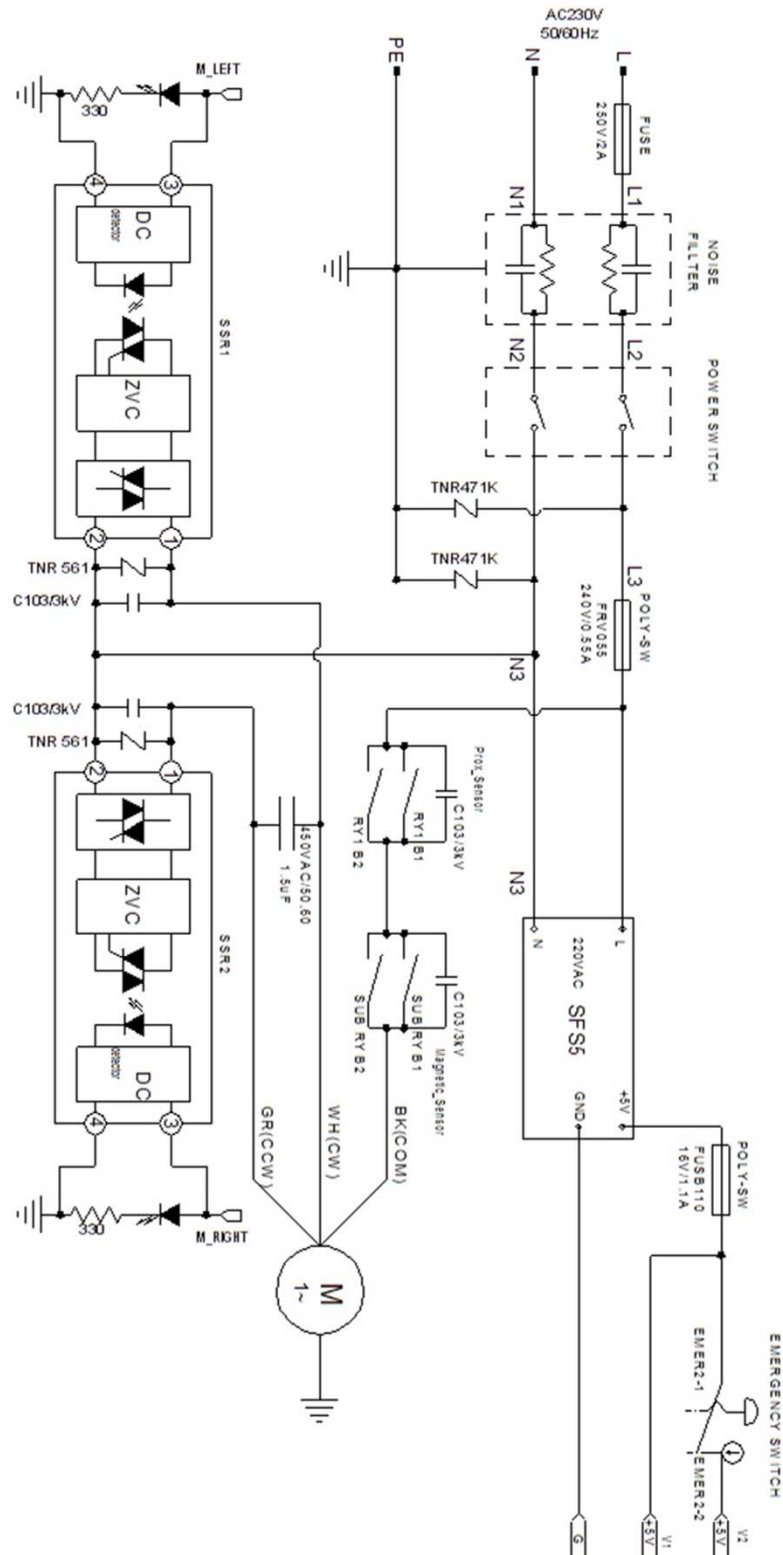

SUB BOARD

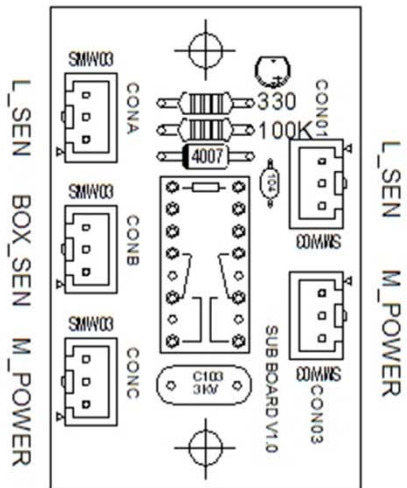
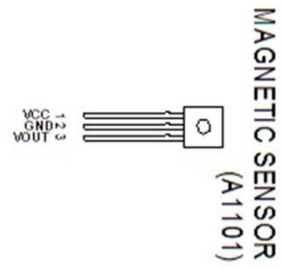
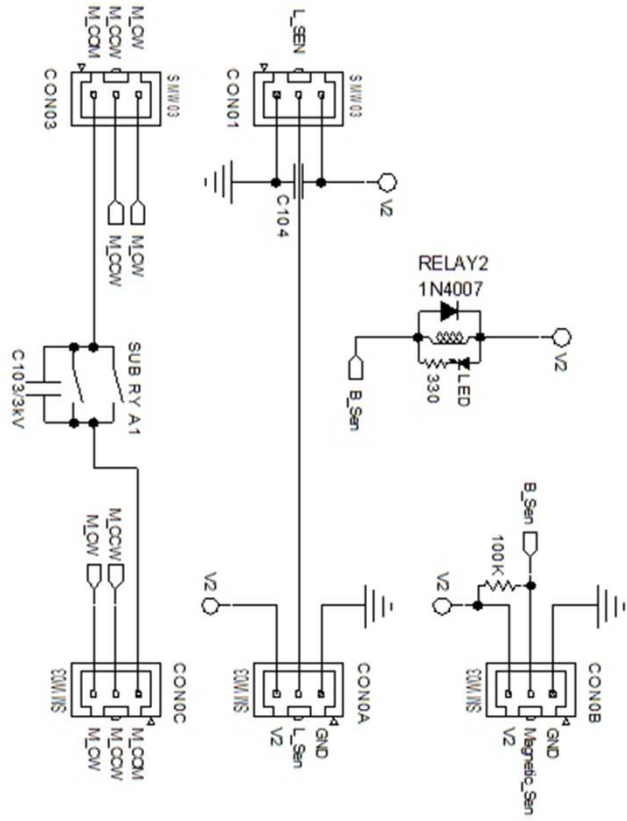

PART NUMBERS

MAJOR COMPONENTS

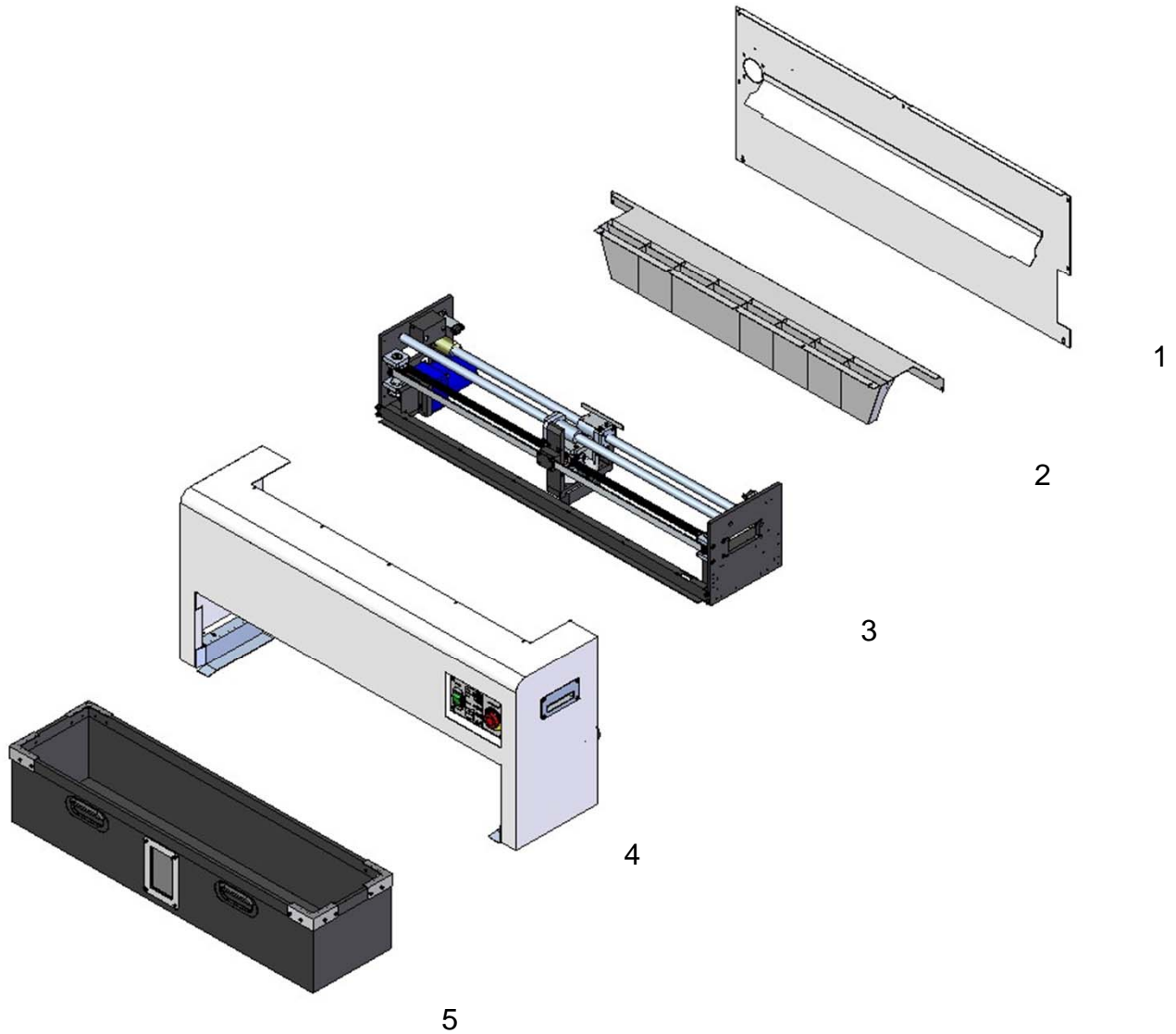

<u>ITEM</u>	<u>PART NO.</u>	<u>DESCRIPTION</u>
1	ES_23101003	Rear Cover
2	ES_23101002	Inlet Guide
3	ES_23649004	Cutting Mechanism
4	ES_23101001	Housing
5	ES_23649003	Trash Bin

PART NUMBERS

23649004: CUTTING MECHANISM

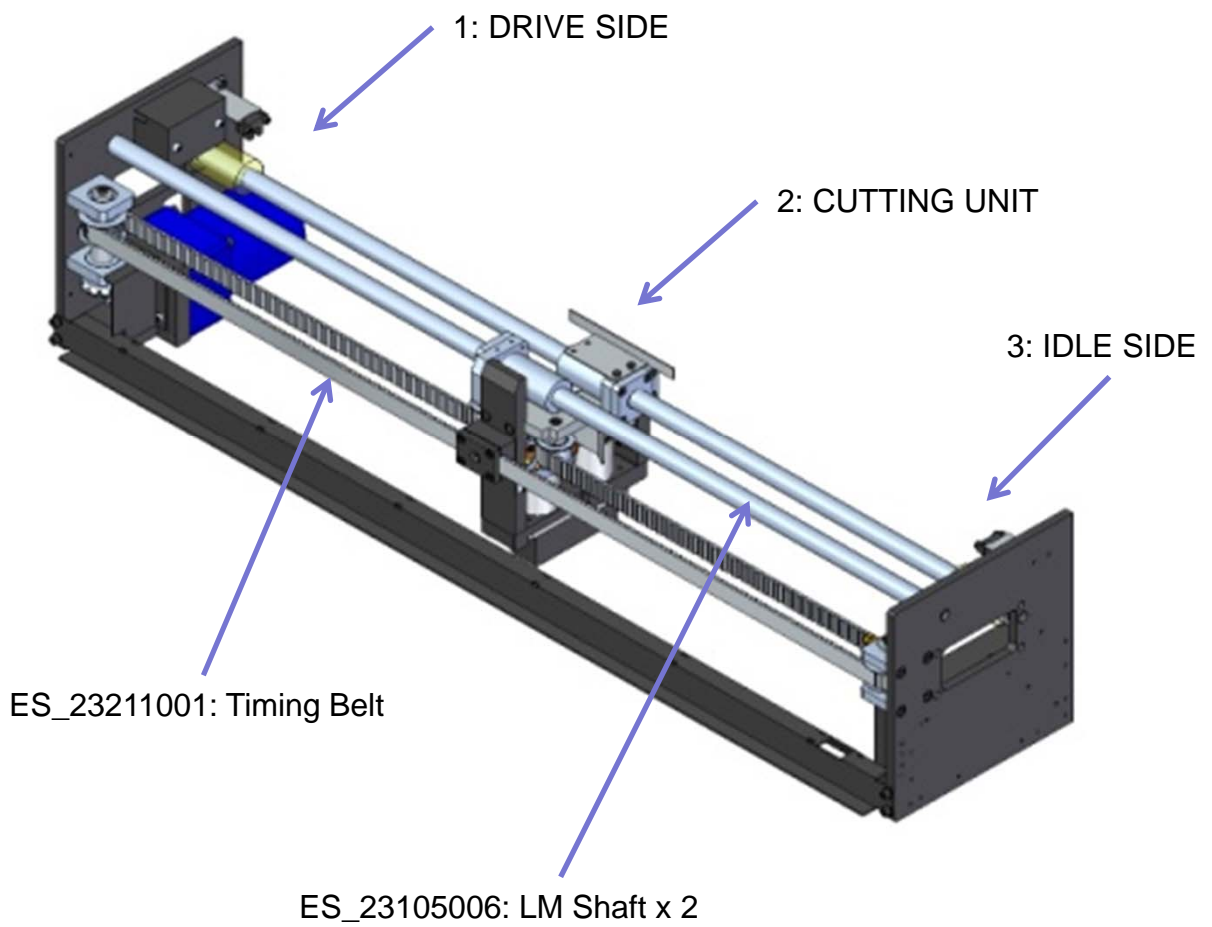

PART NUMBERS

1. Drive Side

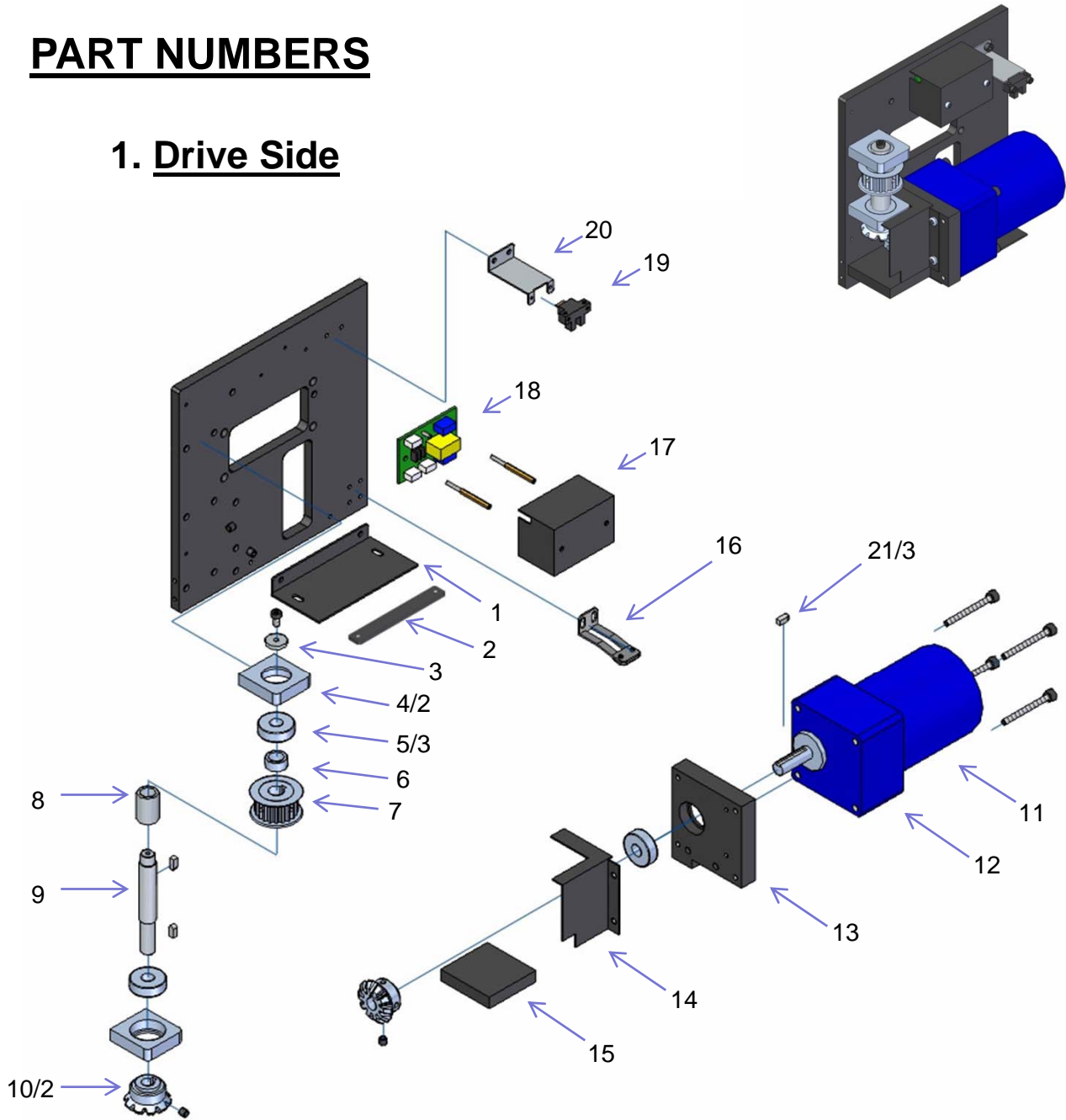

<u>ITEM</u>	<u>PART NO.</u>	<u>DESCRIPTION</u>
1	ES_23149040	Joint Bracket - L
2	ES_23149064	Plate Nut - Joint Bracket
3	ES_23149011	Washer d16x3t
4	ES_23149020	Support Plate - Drive Shaft
5	ES_23210002	Ball Bearing 6000
6	ES_23149019	Spacer - d16x7.7
7	ES_23509001	Pulley 19.2
8	ES_23149009	Spacer - d16x22.7
9	ES_23105003	Drive Shaft
10	ES_23103005	Bevel Gear

<u>ITEM</u>	<u>PART NO.</u>	<u>DESCRIPTION</u>
11	ES_23370001	Motor
12	ES_23377001	Gear Head Assembly
13	ES_23149023	Motor Plate
14	ES_23149036	Gear Cover
15	ES_23149024	Support Plate
16	ES_23549015	Magnetic Sensor
17	ES_23149073	Mag Sensor Controller Cover
18	ES_23374001	Magnetic Sensor Controller
19	ES_23372001	Sensor
20	ES_23149030	Bracket
21	ES_23149079	Key 4x4.1x9.5L

PART NUMBERS

2. Cutting Unit

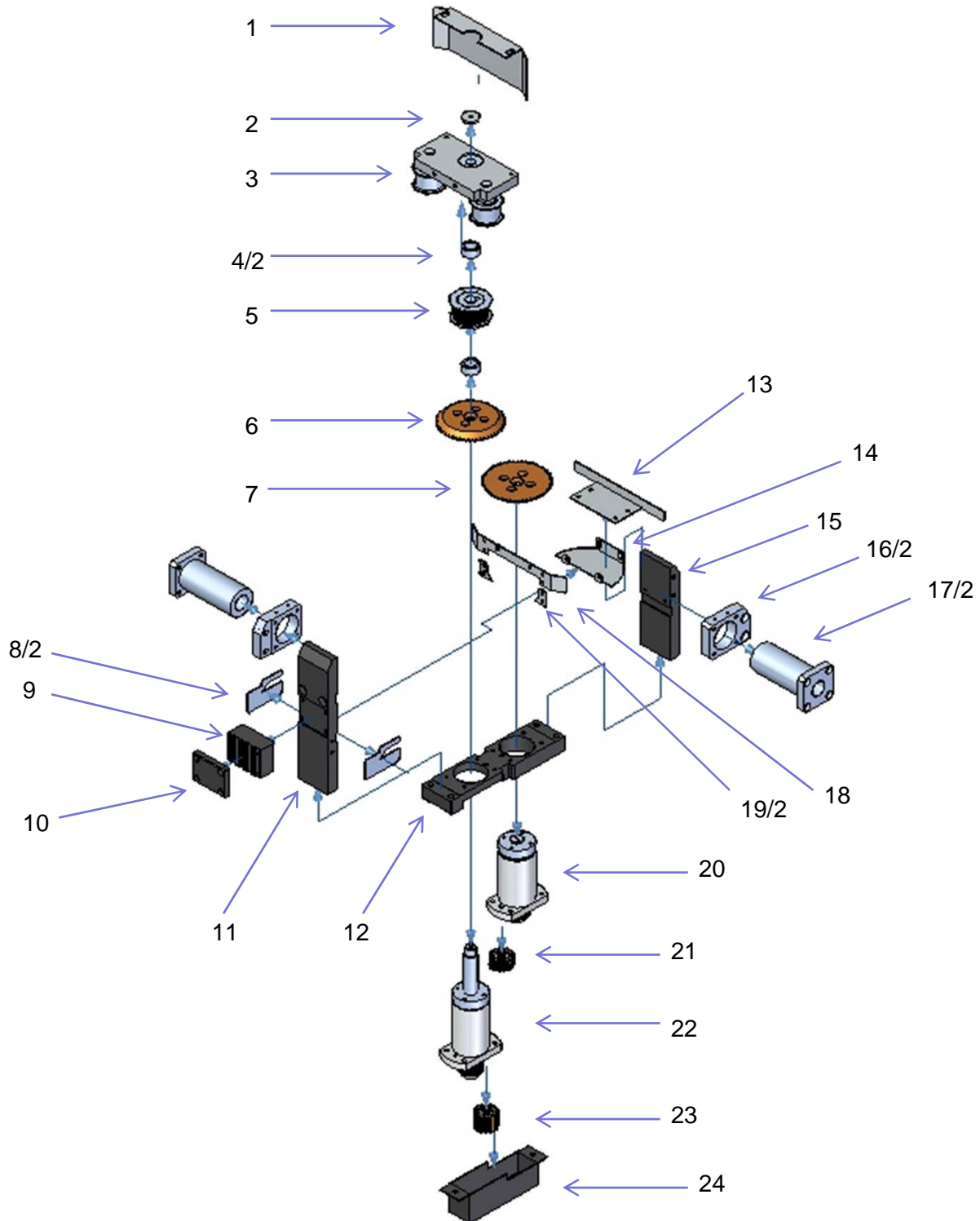

PART NUMBERS

2. Cutting Unit cont.

<u>ITEM</u>	<u>PART NO.</u>	<u>DESCRIPTION</u>
1	ES_23149026	Upper Blade Shield
2	ES_23149011	Washer d16x3t
3	ES_23549008	Belt Guide Subassembly
4	ES_23149019	Spacer - Pulley d16x7.7
5	ES_23509001	Pulley 19.2
6	ES_23102001	Upper Blade
7	ES_23102002	Lower Blade
8	ES_23149078	Upper Blade Cover
9	ES_23149018	Belt Holder
10	ES_23149017	Belt Clamp
11	ES_23149013	Front Block
12	ES_23149012	Slider Body
13	ES_23149029	Sensor Dog
14	ES_23149025	Lower Blade Shield
15	ES_23149014	Rear Block
16	ES_23149016	LM Bearing Holder
17	ES_23210006	LM Bush
18	ES_23149057	Lower Blade Cover
19	ES_23149053	Blade Cover - NC3
20	ES_23549001	Lower Blade Drive
21	ES_23503004	Helical Gear - 21x11
22	ES_23549002	Upper Blade Drive
23	ES_23503001	Helical Gear - 21x17
24	ES_23149034	Gear Cover - Slider

PART NUMBERS

2. Cutting Unit cont.

23549008: Belt Guide Subassembly

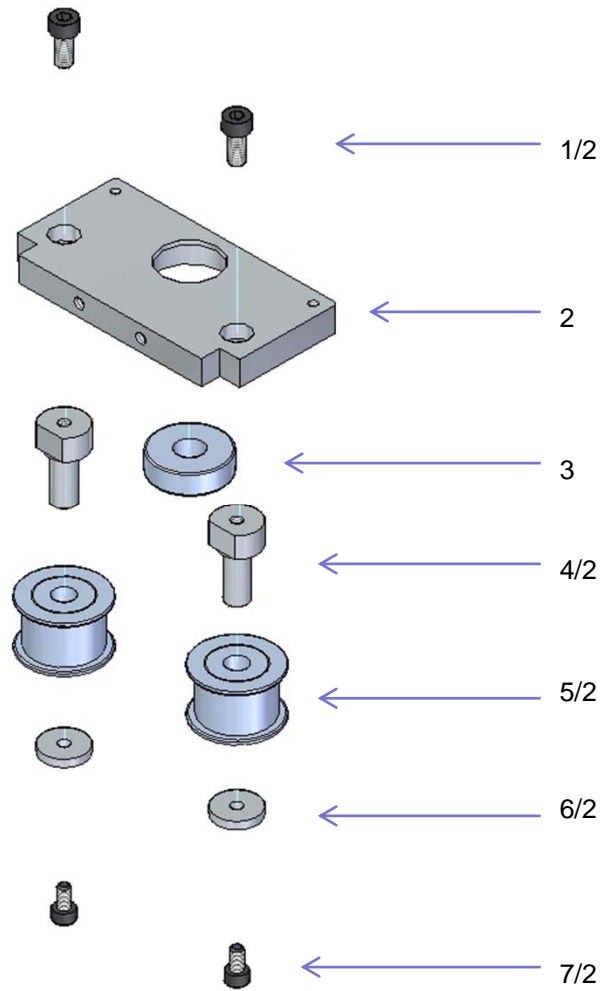

<u>ITEM</u>	<u>PART NO.</u>	<u>DESCRIPTION</u>	<u>ITEM</u>	<u>PART NO.</u>	<u>DESCRIPTION</u>
1		M5 Socket Cap Screw	5	ES_23508001	Idle Roller
2	ES_23149015	Support Plate - Slider	6	ES_23149011	Washer d16x3t
3	ES_23210002	Ball Bearing 6000	7		M4 Socket Cap Screw
4	ES_23105004	Idle Shaft d16x28.6			

PART NUMBERS

3. Idle Side

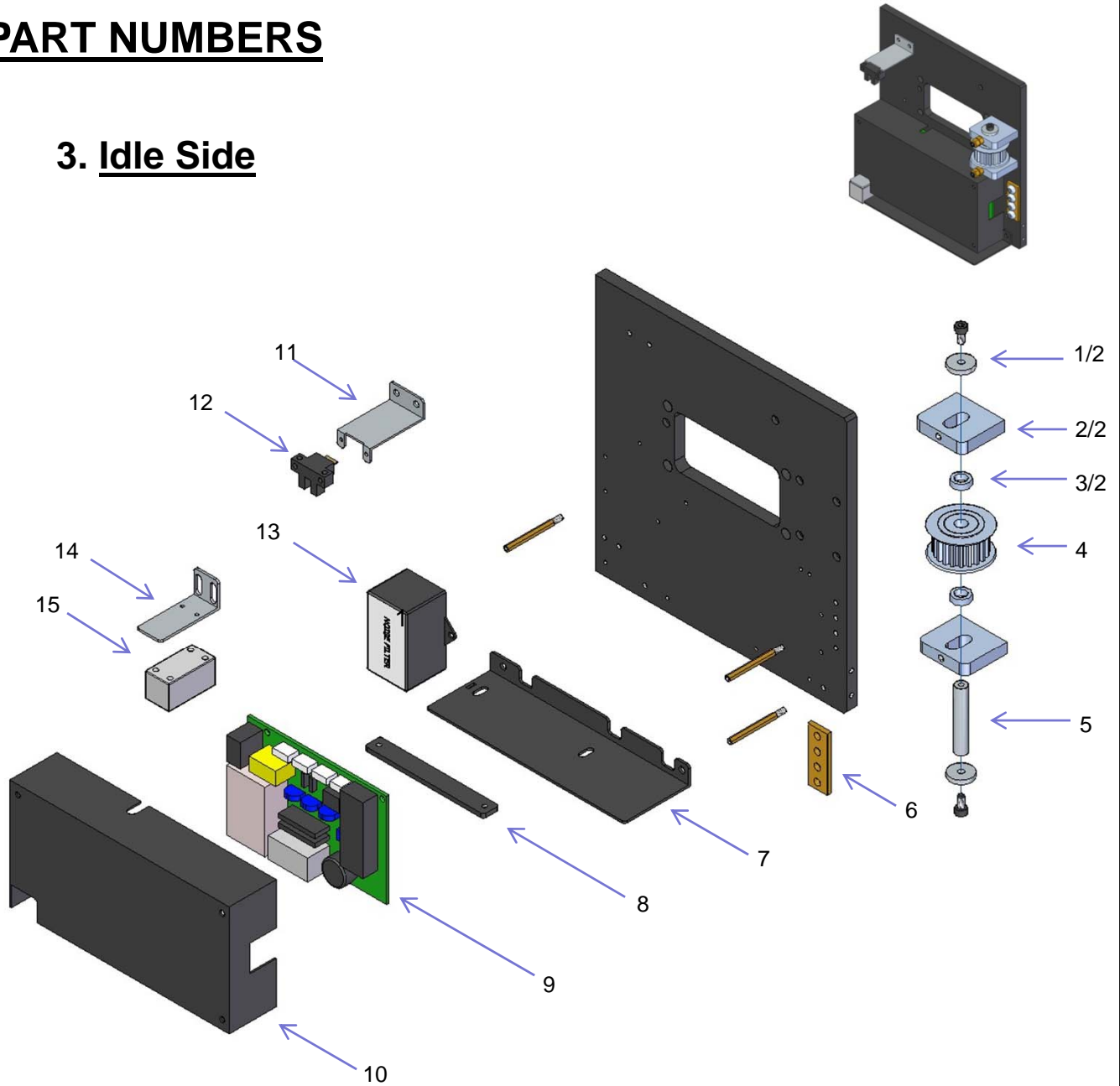

ITEM	PART NO.	DESCRIPTION
1	ES_23149011	Washer d16x3t
2	ES_23149021	Idle Block
3	ES_23149031	Spacer d12x4
4	ES_23509003	Pulley 20
5	ES_23105005	Idle Shaft d8x44
6	ES_23149032	Ground Bar
7	ES_23149041	Joint Bracket - R
8	ES_23149064	Plate Nut - Joint Bracket

ITEM	PART NO.	DESCRIPTION
9	ES_23371001	PC Board Assy
10	ES_23149038	Box Cover
11	ES_23149030	Bracket
12	ES_23372001	Sensor
13	ES_23374002	Noise Filter
14	ES_23149042	Proximity Sensor Bracket
15	ES_23372002	Proximity Sensor

Auxiliary parts come with a new machine

- (1) POWER CORD
- (2) GROUND WIRE
- (3) FUSE (1A) (1 pc)